

ユニオン(リング式)

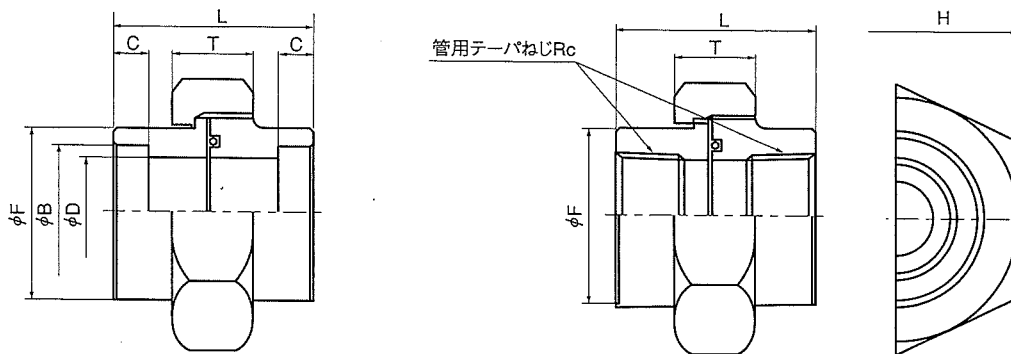

SW U(OR)

Rc(PT) U(OR)

単位:mm

炭素鋼

呼称	記号	B	F	C	D		T	H	L	Rc	リング JIS B2401
					1欄	2欄					
A	B	Sch 80									
8A	1/4	14.3	22.0	10.0	9.4	7.8	15.0	35.0	35.0	1/4	P16
10A	3/8	17.8	27.0	13.0	12.7	10.9	18.0	41.0	40.0	3/8	P20
15A	1/2	22.2	32.0	13.0	16.1	14.3	20.0	46.0	46.0	1/2	P22
20A	3/4	27.7	38.0	14.0	21.4	19.4	23.0	54.0	49.0	3/4	G30
25A	1	34.5	46.0	16.0	27.2	25.0	27.0	63.0	65.0	1	G35
32A	1 1/4	43.2	56.0	18.0	35.5	32.9	30.0	77.0	68.0	1 1/4	G45
40A	1 1/2	49.1	63.0	19.0	41.2	38.4	32.0	85.0	76.0	1 1/2	G50
50A	2	61.1	75.0	22.0	52.7	49.5	35.0	95.0	85.0	2	G65
65A	2 1/2	77.1	95.0	26.0	65.9	62.3	39.0	130.0	99.0	2 1/2	G80
80A	3	90.0	110.0	29.0	78.1	73.9	48.0	150.0	118.0	3	G90

※ねじ込み式ユニオン32A~80Aは2面割りを施しています。 ※ナットは8A~50Aまでは六角形、65A、80Aは八角形。

ステンレス鋼

呼称	記号	B	F	C	D		T	H	L	Rc	リング JIS B2401
					1欄	2欄					
A	B	Sch 80									
8A	1/4	14.3	22.0	10.0	9.4	7.8	17.0	35.0	37.0	1/4	P16
10A	3/8	17.8	25.0	10.0	12.7	10.9	18.0	38.0	38.0	3/8	P20
15A	1/2	22.2	32.0	10.0	16.1	14.3	20.0	46.0	40.0	1/2	G25
20A	3/4	27.7	38.0	13.0	21.4	19.4	21.0	54.0	45.0	3/4	G30
25A	1	34.5	45.0	13.0	27.2	25.0	25.0	63.0	57.0	1	G35
32A	1 1/4	43.2	55.0	13.0	35.5	32.9	25.0	74.0	57.0	1 1/4	G45
40A	1 1/2	49.1	62.0	13.0	41.2	38.4	28.0	83.0	64.0	1 1/2	G50
50A	2	61.1	75.0	16.0	52.7	49.5	32.0	102.0	72.0	2	G65
65A	2 1/2	77.1	95.0	16.0	65.9	62.3	42.0	128.0	82.0	2 1/2	G80
80A	3	90.0	110.0	16.0	78.1	73.9	46.0	147.0	88.0	3	G90

※ねじ込み式ユニオンは2面割りを施しています。 ※ナットは8A~25Aまでは六角形、32A~80Aまでは八角形。